

Catena doppia per elevatori a tazze, con perni trasversali

Double chain for bucket elevators, linked by crosspiece pins

Cadena doble para elevator de cangilones unida por ejes travesaños

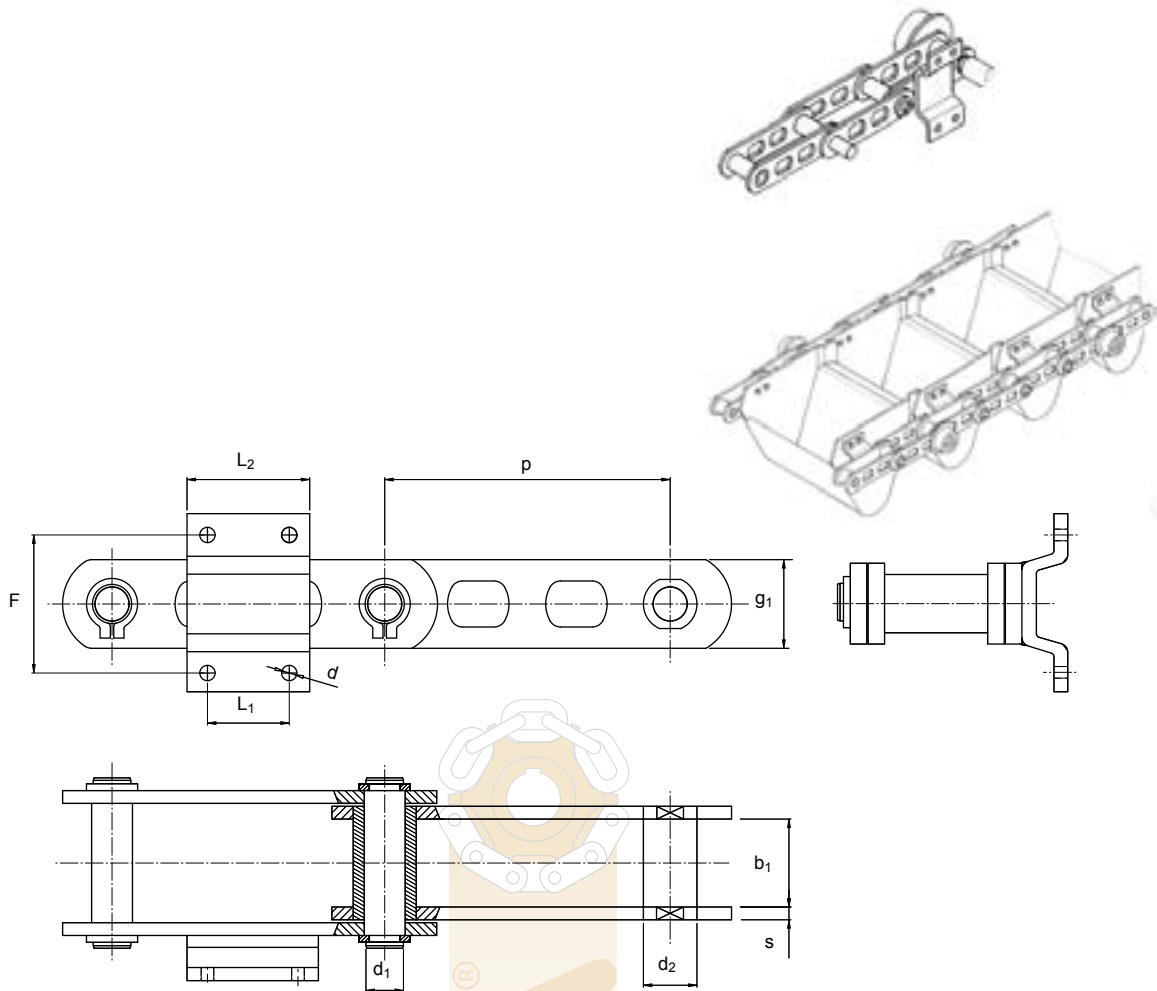

Codice Code Código	Dimensioni / Dimensions / Dimensiones mm											MBF kN	
	Passo Pitch Paso P	b₁	Ø d	Ø Bussola Bush Casquillo d₂	Ø Perno Pin Eje d₁	F	L₁	L₂	g₁	s	Ø Rullo flangiato Flanged roller Rodillo pestaña		Ø Perno trasversale Crosspiece pin Eje traves
SUR-50	200	45	14	32	22	110	60	100	50	8	50	22-28	200
SUR-60	250	65	18	45	32	150	80	120	70	10	60	32-40	320
SUR-70	250	67	18	50	35	150	80	120	80	12	70	35-45	480
SUR-100	280	79	21	58	40	150	80	130	100	12	70	40-45	750
SUR-80	400	79	25	60	42	150	80	140	110	15	80	-	1000